

Owners Manual

Models 4420BF1U & 4420BF1L

Floor Mounted Bi-Level Bottle Filler Tubular Fountain

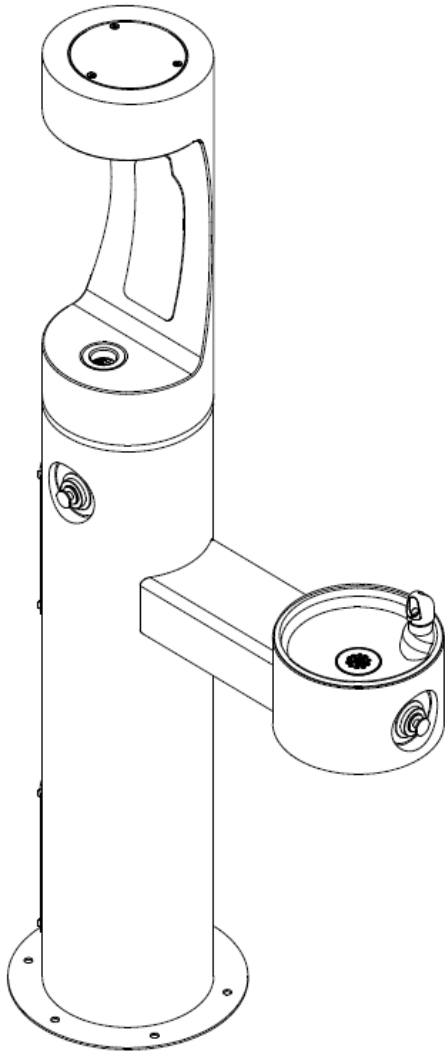

Models (LK)4420BF1U*

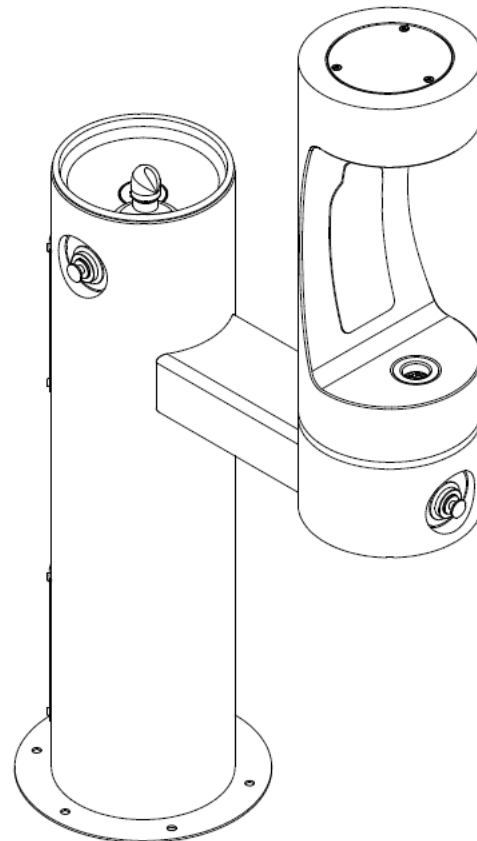

Models (LK)4420BF1L*

INSTALLER

4420BF Fountains are among the easiest to install Fountains on the market today. To assure you install these models easily and correctly, PLEASE READ THESE SIMPLE INSTRUCTIONS BEFORE STARTING THE INSTALLATION. CHECK YOUR INSTALLATION FOR COMPLIANCE WITH PLUMBING, ELECTRICAL, AND OTHER APPLICABLE CODES. After installation, leave these instructions with the Fountain for future reference.

INSTALLATION INSTRUCTIONS

IMPORTANT

ALL SERVICE TO BE PERFORMED BY AN AUTHORIZED SERVICE PERSON

IMPORTANT! INSTALLER PLEASE NOTE.

THE GROUNDING OF ELECTRICAL EQUIPMENT SUCH AS TELEPHONE, COMPUTERS, ETC. TO WATER LINES IS A COMMON PROCEDURE. THIS GROUNDING MAY BE IN THE BUILDING OR MAY OCCUR AWAY FROM THE BUILDING. THIS GROUNDING CAN CAUSE ELECTRICAL FEEDBACK INTO A FOUNTAIN, CREATING AN ELECTROLYSIS WHICH CAUSES A METALLIC TASTE OR AN INCREASE IN THE METAL CONTENT OF THE WATER. THIS CONDITION IS AVOIDABLE BY USING THE PROPER MATERIALS AS INDICATED. ANY DRAIN FITTINGS PROVIDED BY THE INSTALLER SHOULD BE MADE OF PLASTIC TO ELECTRICALLY ISOLATE THE FOUNTAIN FROM THE BUILDING PLUMBING SYSTEM.

1. This fountain is to be mounted on a smooth, flat, finished surface with adequate support structure. NOTE: Mounting structure must be capable of supporting 300 lb. load on fountain.
2. Refer to rough-in for plumbing.
3. Install shut-off valve on water supply. (Valve not furnished)
4. Locate and install fountain using 3/8" minimum fasteners. (Fasteners not furnished)
5. Prior to installing the bottle filler to the center mounting position of fountain, install the drain pipe (Item #11) by positioning the short end of drain pipe through mounting plate of bottle filler. Next, place the aesthetic collar (Item # 26) onto the center mounting position of the fountain ensuring the vertical edge of the collar is upright and the curved edge sits below the mounting surface. Mount bottle filler to fountain with collar centered between the two pieces. Secure with supplied hardware.
6. Prior to installing the bottle filler to the arm mount of fountain, insert the drain pipe (Item #10) into the arm tunnel and adjust drain to lean to the left side of arm when facing button. place the aesthetic collar (Item # 26) onto the arm mounting position of the fountain ensuring the vertical edge of the collar is upright and the curved edge sits below the mounting surface. Mount bottle filler to arm with collar centered between the two pieces Install bottle filler to arm being sure drain tube is above mounting plate of filler. Install filler onto fountain and secure with supplied mounting hardware.
7. Connect water supply and fountain drain. Connect drain waste "Tee" to fountain drain tubes. Connect outlet of "Tee" to drainage system. Connect Bottle Filler water line to regulator with the supplied 3/8" to 1/4" reducing fitting. Water connection and drain must comply with local codes.
8. Turn on water supply and check all connections for leaks.
9. Water supply 3/8" O.D. unplated copper tube. Waste 1-1/2" IPS. Contractor to supply waste trap and service stop valve in accordance with local code.
10. Connecting lines to be made of unplated copper and should be thoroughly flushed to remove all foreign matter before being connected to fountain. This fountain is manufactured in such a manner that it does not in any way cause taste, odor, color, or sediment problems.
11. Connect fountain to supply line with a shut-off valve and install a 3/8" unplated copper water line between the valve and the cooler. Remove any burrs from outside of water line. Push the tubes straight into the fittings until they reach a positive stop, approximately 3/4" (See Fig. 2). DO NOT SOLDER TUBES INSERTED INTO PLASTIC FITTINGS AS DAMAGE TO THE O-RINGS MAY RESULT.

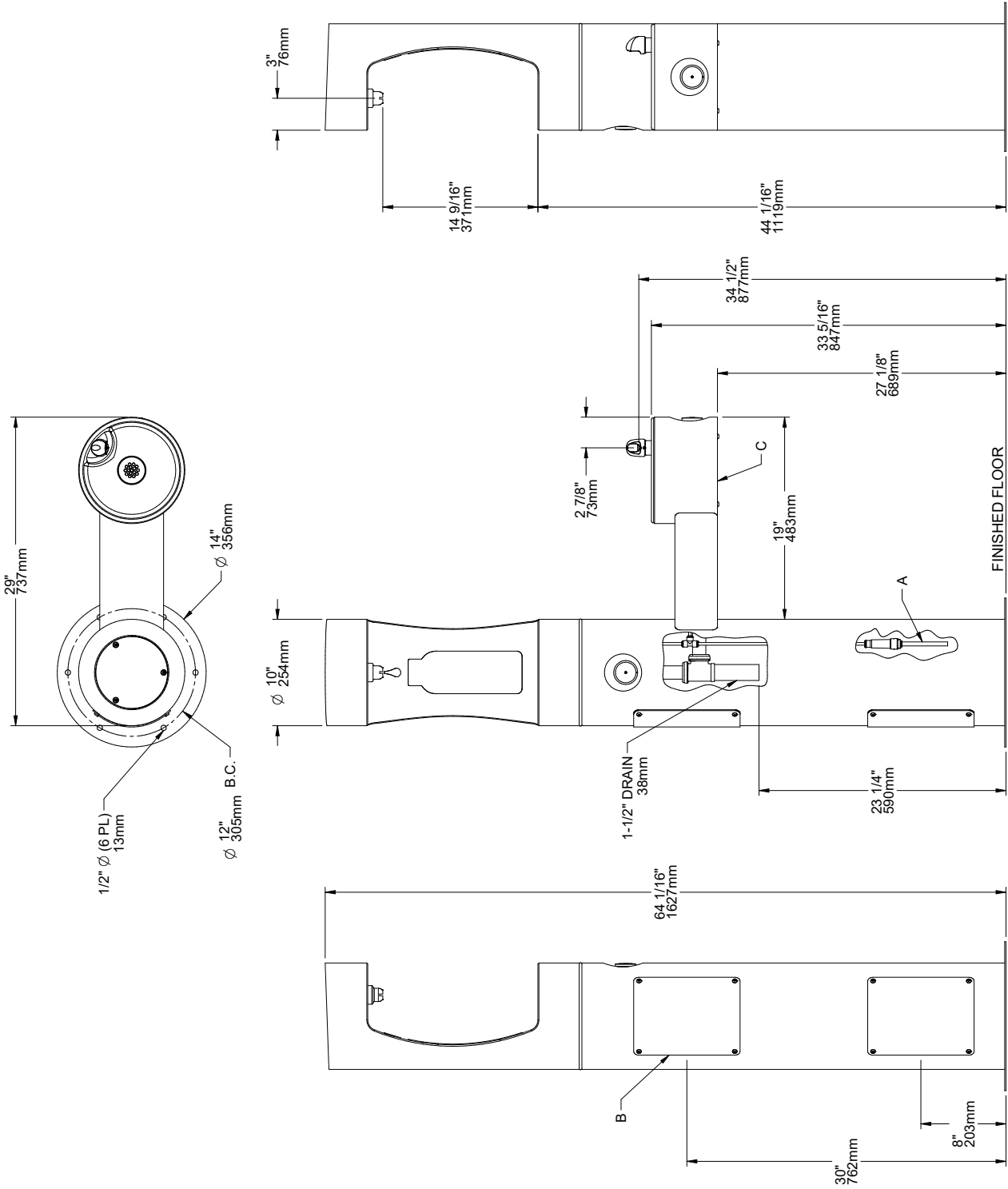

LEGEND
 A = 3/8" O.D. UNPLATED COPPER TUBE CONNECT - SHUT OFF VALVE BY OTHERS
 B = ACCESS PANEL (8" X 10")
 C = REMOVABLE BOTTOM COVER

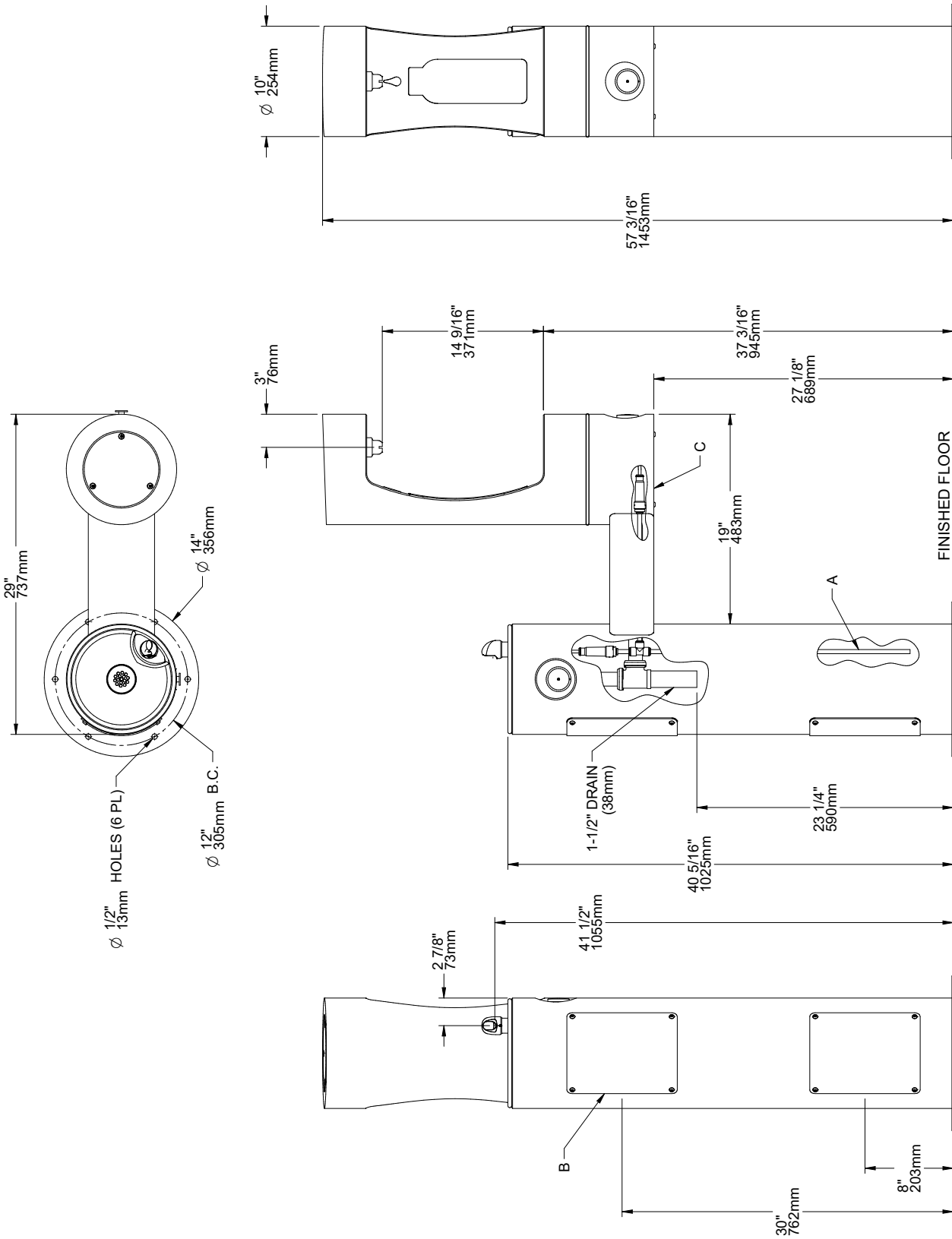

4420BF1L

LEGEND
 A = 3/8" O.D. UNPLATED COPPER TUBE CONNECT - SHUT OFF VALVE BY OTHERS
 B = ACCESS PANEL (8" X 10")
 C = REMOVABLE BOTTOM COVER

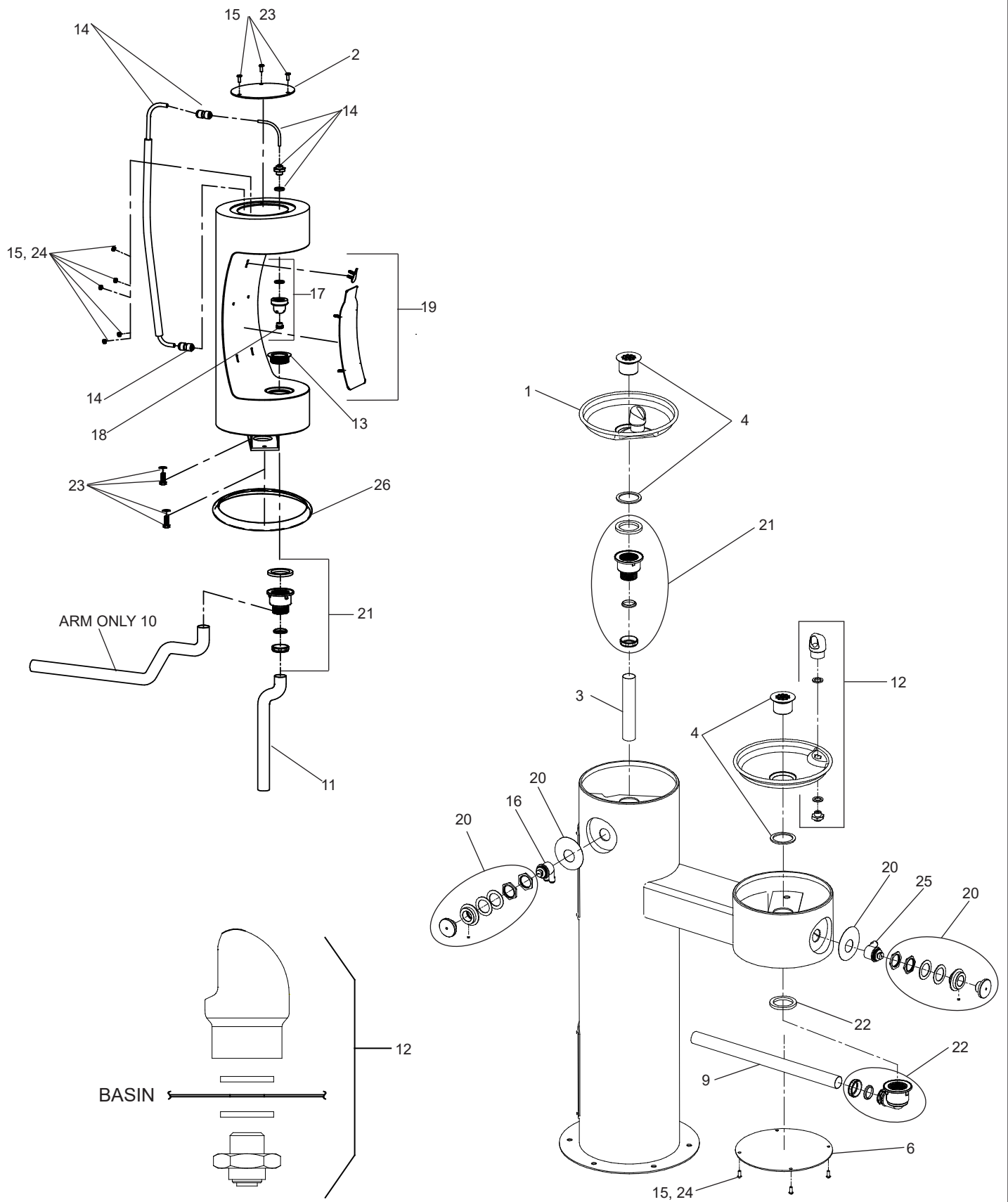

Vandal-Resistant Bubbler
FIG. 1

TROUBLE SHOOTING AND MAINTENANCE

ACTUATION OF QUICK CONNECT WATER FITTINGS:

Fountain is provided with lead-free connectors which utilize an o-ring water seal. To remove tubing from the fitting, relieve water pressure, push in on the gray collar while pulling on the tubing. (see Fig.3) To insert tubing, push tube straight into fitting until it reaches a positive stop, approximately 3/4".

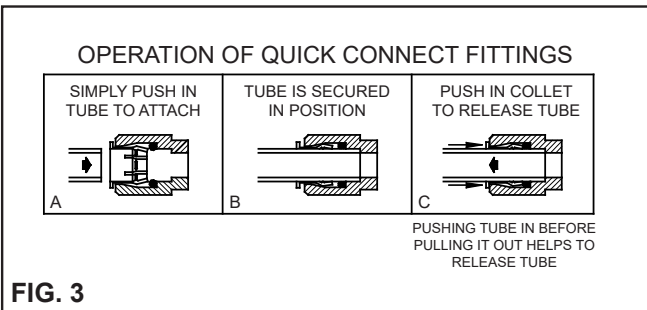
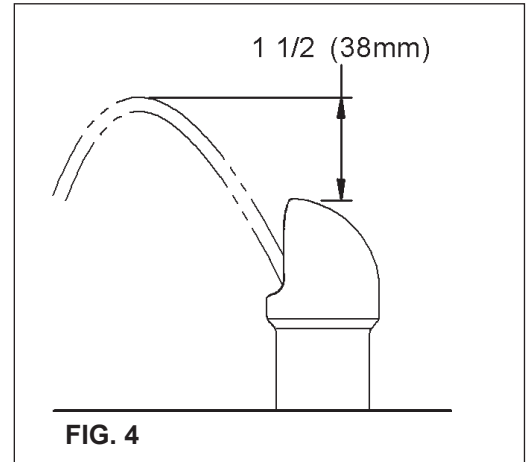
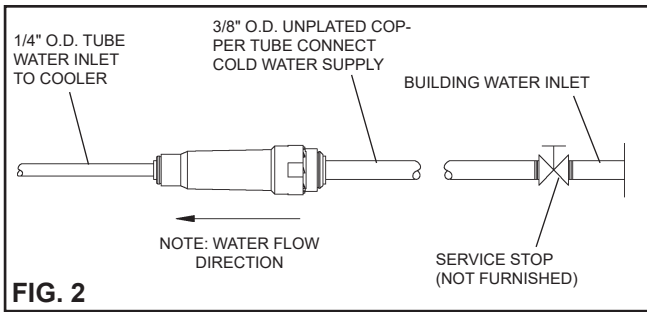

STREAM HEIGHT ADJUSTMENT:

Stream height is factory set at 35 PSI. If supply pressure varies greatly from this, insert a small straight bladed screwdriver through the access hole in the center of the push button and turn the adjustment screw. Clockwise adjustment will raise the stream and counterclockwise adjustment will lower the stream. For best adjustment, the stream should be approximately 1-1/2" above the top of the bubbler. (See Fig. 4)

ITEMIZED PARTS LIST

ITEM NO.	PART NO.	DESCRIPTION
1	28467C	Basin
2	1000003814*	Cover - Round Plate
3	40551C	Tailpipe
4	0000000325	Kit - Drain Plug/Gasket
5	1000003812*	Access Panel
6	1000003813*	Bottom Cover
7	45476C	Drain Tube
8	55996C	In - Line Strainer
9	66346C	Drain Tube
10	66816C	Tube - Drain (Arm Only)
11	66815C	Tube - Drain
12	97446C	Kit - Bubbler (VR)
13	45931C	Outdoor Bottle Filler Drain Plug
14	98686C	Kit - (BF) Waterway/Nipple/Gasket/Tubes/Ftgs
15	98685C	Kit - Hardware/Bolts/Nuts/Washers/VR Torx Screws
16	98678C	Kit - 1.0 GPM Regulator (BF Only)
17	98679C	Kit - Nozzle/Aerator/Gasket/Pin
18	98680C	Kit - Aerator/Key
19	98681C	Kit - Blank Bottle Filler Trim
	1000003692	Kit - LK4420BF Bottle Filler Trim
	1000003693	Kit - 4420BF Bottle Filler Trim
20	98682C	Kit - Push Button w/Blank Nameplate
	1000003694	Kit - Push Button w/LK4420BF Nameplate
	1000003695	Kit - Push Button w/4420BF Nameplate
21	98683C	Kit - Drain Adapter/Gasket/Nut/Washer
22	98684C	Kit - Drain Elbow/Gasket/Nut/Washer
23	75724C	Screw - 1/4"x20 x 3/4" LG. Pinned Torx
24	97247C	Kit - VR Screws/Bit
25	98733C	Kit - Regulator/Holder/Nuts
26	1000005456	Aesthetic Collar

*select color option to complete part number

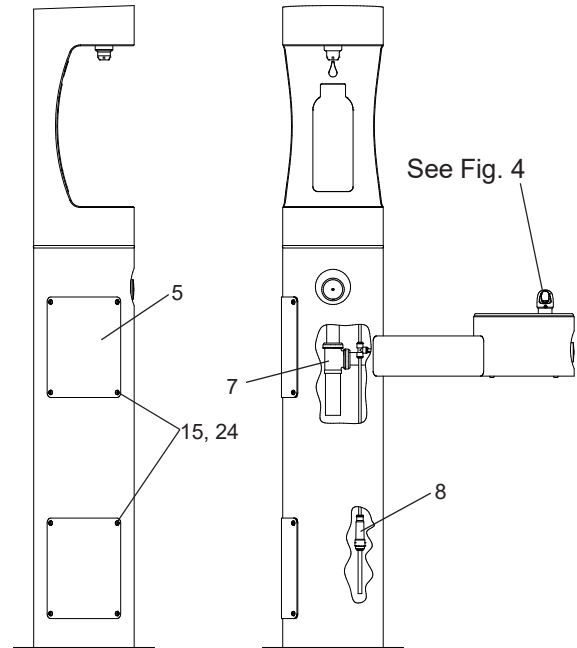

***FINISH COLOR OPTIONS - Choose color option to complete your model number, add as suffix example: 4420BF EVG**

Matte finish: Evergreen = EVG

- Gloss finish:
- Beige = BGE
 - Black = BLK
 - Blue = BLU
 - Brown = BRN
 - Gray = GRY
 - Orange = ORN
 - Purple = PUR
 - Red = RED
 - Terracotta = TER
 - White = WHT
 - Yellow = YLW

Owners Manual

Outdoor Bottle Filler Foot Pedal Accessory For Use On Following Series Fountains With Floor Mount Base

Elkay Series:

LK4400BF
LK4420BF1U
LK4420BF1UDB

Halsey Taylor:

4400BF
4420BF1U
4420BF1UDB

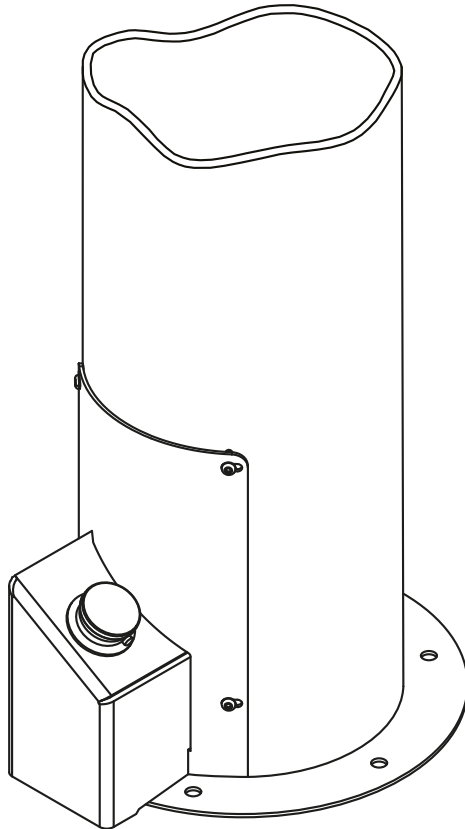

Installer

To assure you install this accessory easily and correctly, PLEASE READ THESE SIMPLE INSTRUCTIONS BEFORE STARTING THE INSTALLATION. CHECK YOUR INSTALLATION FOR COMPLIANCE WITH PLUMBING, ELECTRICAL AND OTHER APPLICABLE CODES.

INSTALLATION INSTRUCTIONS

- 1) Shut off the water to the fountain. Press the push button(s) to relieve the remaining water pressure from the unit.
- 2) Using the supplied T-27 torx head bit and a bit holder, remove all 8 screws securing the upper and lower access panels located on the side of the fountain. See Fig.7 and 5.

Note: Foot pedal will replace the lower access panel.

- 3) Through the lower access panel opening, locate the 3/8" water inlet copper tube at the bottom of the fountain and cut it, leaving enough on both sides to insert the supplied 3/8" Tee.
- 4) Take one of the 3/8" Tees and insert the copper tube, in-line strainer and 6" of the 1/4" poly tubing as shown. After assembled, attach the 3/8" Tee to the 3/8" water inlet copper tubing where it was cut in Step 3. See Fig.1 and 6.
- 5) Take the 1/4" poly tubing from the water line assembly and insert into the inlet side of the regulator on the foot pedal. See Fig.2 and 6.
- 6) Take the remaining supplied 3/8" Tee and connect one end of the 3/8" poly tubing into it as shown. See Fig.3 and 8.
- 7) Slide the black insulation onto the 3/8" poly tubing and then cut off remaining insulation at the end of the tubing.
- 8) Connect the 3/8" poly tubing to the 3/8" x 1/4" fitting. Cut another 1/4" poly tubing to 6 inches and then insert into the open end of the fitting. See Fig.4 and 6.
- 9) Looking into the fountain from the upper access panel, locate the 3/8" water line leading from the bottle filler push button to the bottle filler; cut it, leaving the enough on both sides to insert the supplied 3/8" Tee. See Fig.3, 7 and 8.
- 10) Place the 3/8" poly tubing inside the fountain body and arrange it to be accessible from the lower access opening. Take the 1/4" poly tubing and insert it into the regulator. See Fig.6.

Panel(s) Installation

- 11) Turn on the main water supply. Check for leaks and ensure proper function of foot pedal and existing push button. If there are leaks, turn off the water supply and correct the water leaks as required.
- 12) After ensuring that all connections are leak free, leave the main water supply on and install the upper access panel with its 4 screws. Use the T-27 torx head bit and a bit holder to tighten. See Fig.7.
- 13) Secure the foot pedal body to the fountain body with the 4 screws provided. Use the T-27 torx head bit holder to tighten. See Fig.5.
- 14) Installation of foot pedal is complete.

TOOLS REQUIRED (NOT PROVIDED)

- 1) Gloves
- 2) Safety Glasses
- 3) Tubing Cutter
- 4) Utility knife
- 5) Bit holder

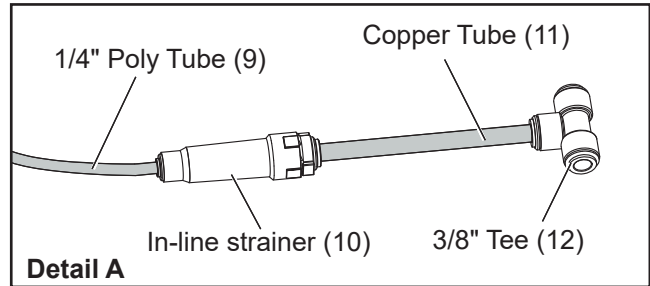

Fig.1

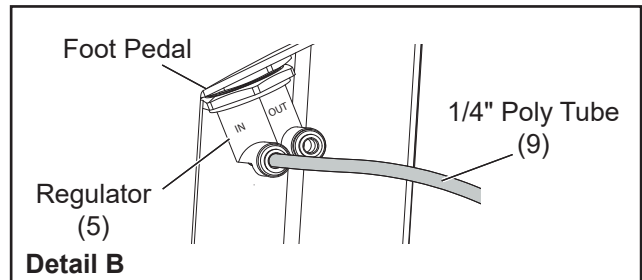

Fig.2

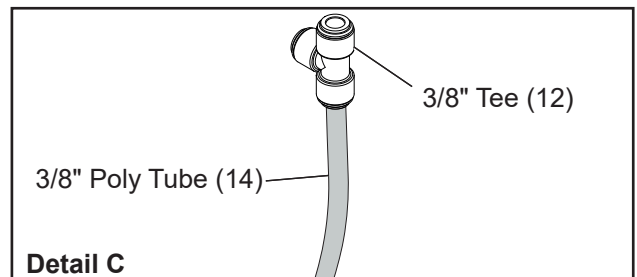

Fig.3

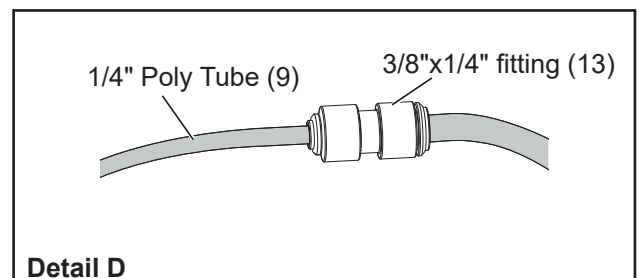
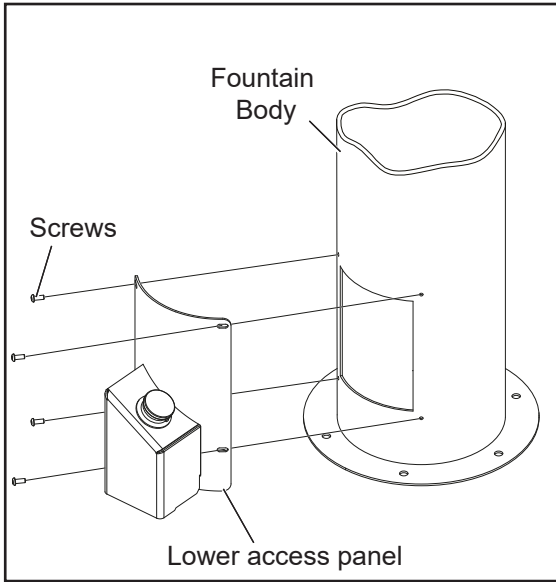
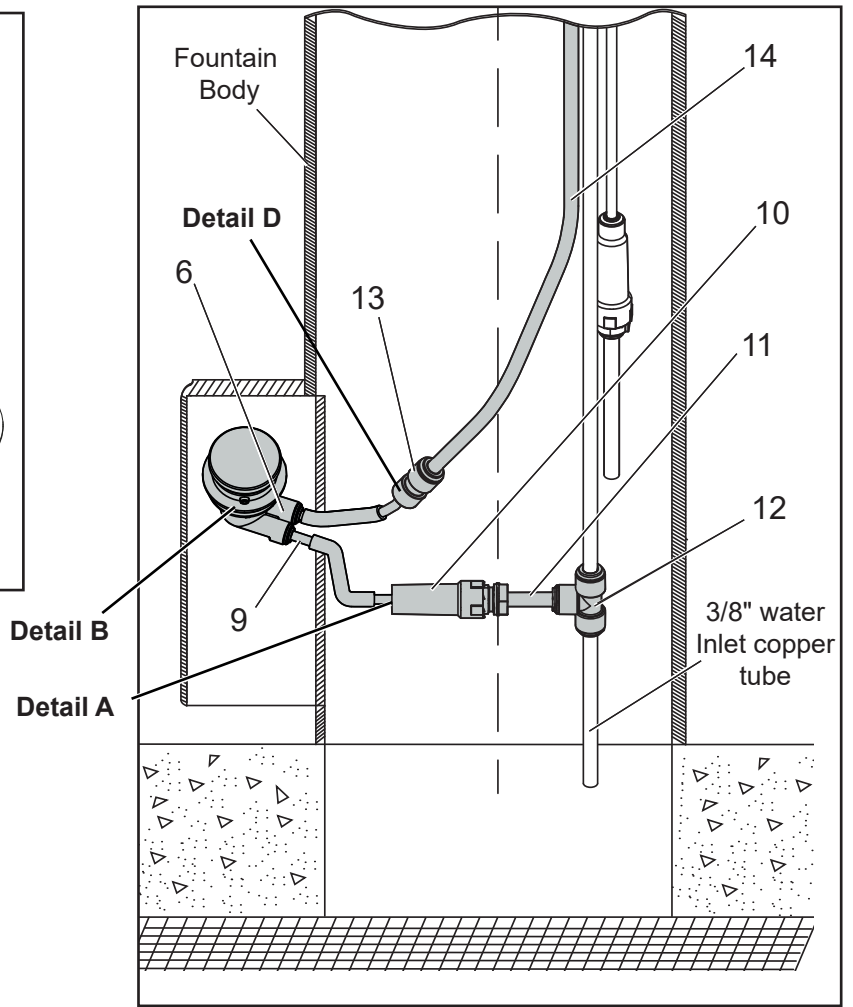

Fig.4

Note: See Fig.6 and Fig.8 for Details A, B, C and D



**Lower Fountain
Fig.5**



**Lower Fountain Internal View
Fig.6**

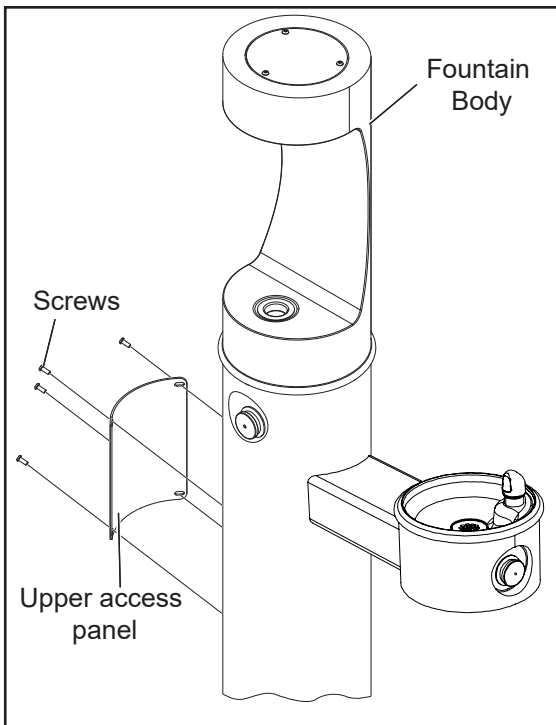

**Upper Fountain
Fig.7**

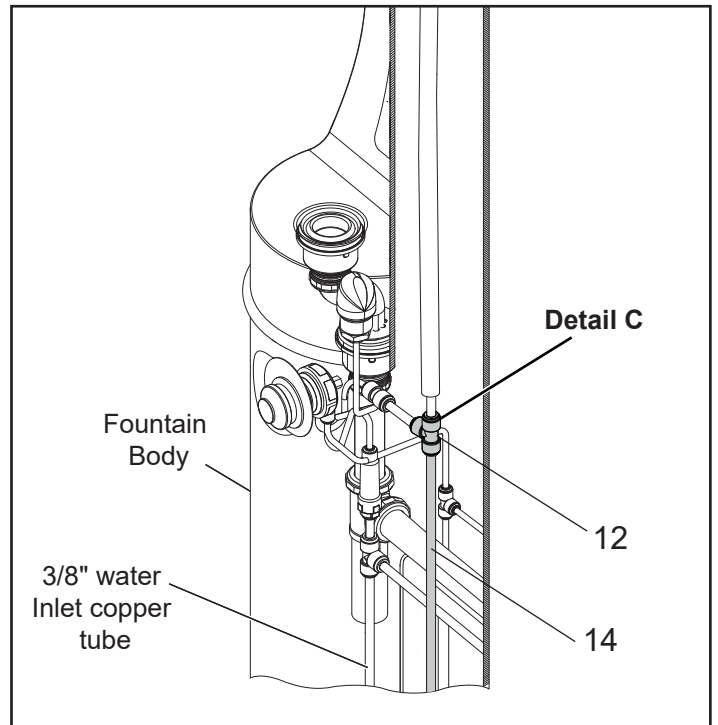

**Upper Fountain Bottle Filler Internal View
Fig.8**

Parts List

ITEM NO.	DESCRIPTION
1	Assy, 4481 FP Foot Activation
2	Washer-Spacer 2.00 O.D.
3	Nut-Hex 1-5/16"
4	1-1/8"-24 Retaining Nut
5	Regulator - High Flow Wras
6	Holder - Regulator
7	Sleeve - Push Button Guide
8	Button - Push w/o Hole
9	Tube-Poly 1/4"X.040 Wall
10	Strainer - In Line Wras
11	Tube - Cu 3/8" X 4.75 (1-P117)
12	Fitting Tee - 3/8"
13	Fitting - Union-3/8" X 1/4 Union
14	Tube-Poly 3/8"X.062 Wall
15	Screw-Cap #6-32
16	Insulator-Tube 3/8"-3/16 Bulk

Replacement Parts List

ITEM NO.	PART NO.	DESCRIPTION
17	1000006235	4481FP - Outdoor Fountain Foot Activation - Push Button Service Kit
18	1000006234	4481FP - Outdoor Fountain Foot Activation - Regulator Service KIT

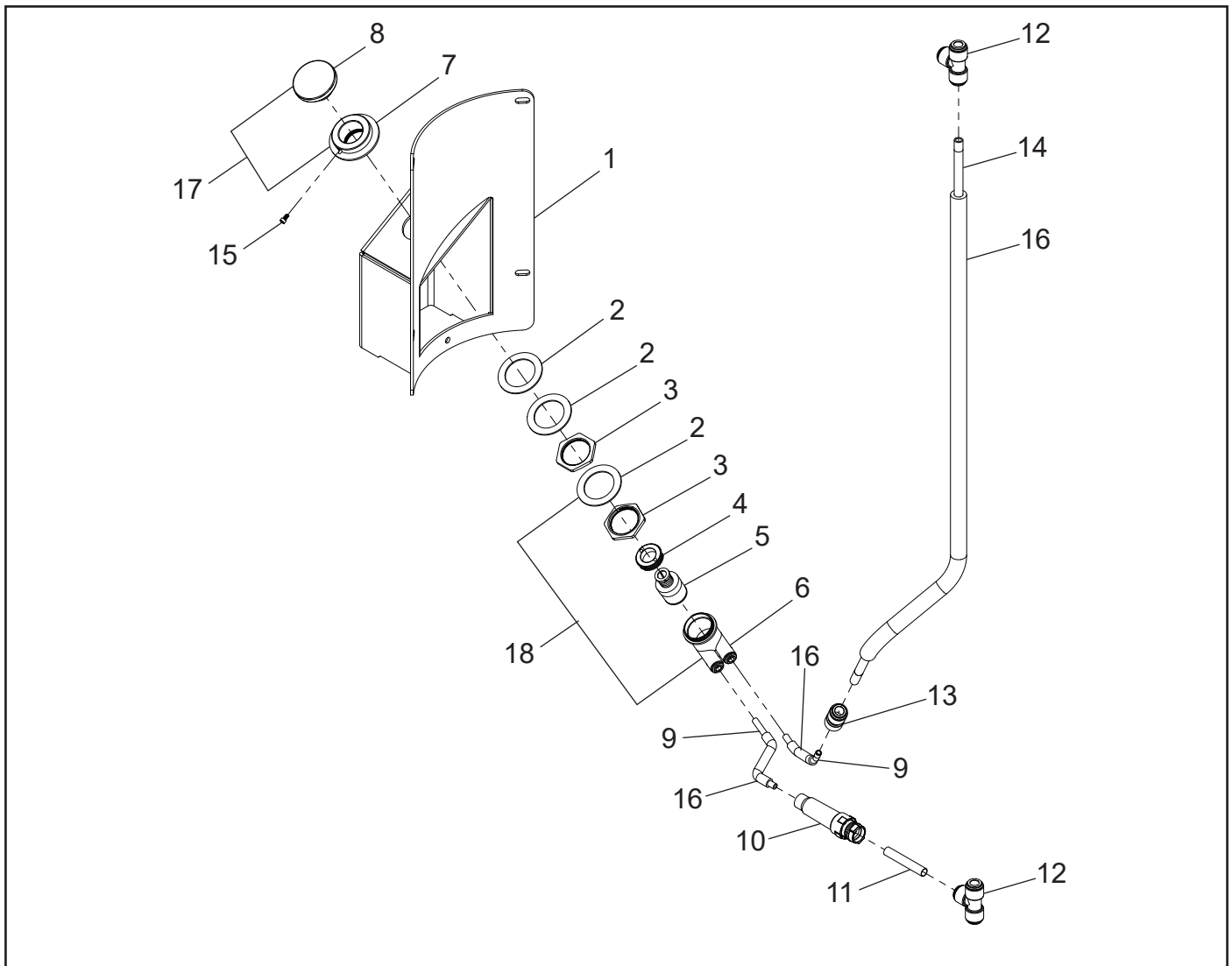

Foot Pedal Exploded View